

AMMANN

MACHINES

ACR SERIES

ACR RAMMER



MINI DIGGER HIRE LTD

REGIONAL SALES: ANDY ROSETHORN

t:07908 498 895
e:sales@ammann-sales.co.uk
www.ammann-sales.co.uk

“The optimal balance and user-friendly handle of the Ammann ACR Rammers make these machines a joy to work with.”



THE RIGHT FIT ON YOUR JOBSITE

AMMANN ACR RAMMERS

Ammann Rammers feature the best movement capabilities in the industry, helping contractors in all applications work productively and ultimately achieve compaction targets. The moving ability makes them the tool of choice for contractors and rental agencies.

The rammers also are so easy to use that operators of all experience levels are able to perform productively. They are more comfortable, too, because of the reduced-vibration handle. That lessens fatigue and ultimately proves to be another productivity booster.



ACR 60

Weight: 62 kg
Compaction force: 11.5 kN
Working width: 280 mm



ACR 68

Weight: 68 kg
Compaction force: 13 kN
Working width: 280 mm



ACR 70 D

Weight: 83 kg
Compaction force: 16 kN
Working width: 280 mm



YOUR BENEFITS AT A GLANCE

WHAT SETS AMMANN RAMMERS APART?

THE HANDLE

A reduced-vibration handle prevents operator fatigue. In addition, the handle can be gripped from all sides, enabling easy access to tight spaces. The operator can turn the machine 180 degrees to reach tight areas while maintaining optimal control of the rammer at all times.

FUEL FLEXIBILITY

The ACR 60 and ACR 68 run on petrol, while the ACR 70D features a diesel engine. Choose the engine that best fits into your fleet and your fuel preferences.

LOW CENTRE OF GRAVITY

A low centre of gravity gives the ACR 60 and ACR 68 outstanding moving abilities that make operation effortless. Balance also is improved, preventing tipping and making it easy for the operator to guide the machine.

THE SHOE FITS

Varied shoe shapes and sizes, help match the rammer to your application. The shoes are easy to switch too; all that's required is the removal of four screws.

THE HEIGHT

A patented process enables Rammer height to be easily adjusted, a significant benefit as the operator attempts to maximise manoeuvrability and comfort throughout the shift.



SETTING THE STANDARD

The handle, the height, proper shoes and a low centre of gravity that enables control make the Ammann Rammers easy to operate regardless of experience level.

TECHNICAL SOLUTIONS FOR YOUR JOBSITE

CUSTOMISED FOR YOUR NEEDS

Quality and productivity need to be built into every machine. Ammann machines have both, and they also are easy to operate.



CYCLONE AIR FILTER

Optional cyclone pre-filter grants long lifetime of your standard filter. The easy to mount and clean filter element is mounted horizontally and can be removed for cleaning by loosening one single screw. The cyclone pre-filter extends the lifetime of your standard filter by up to five times.



TRANSPORT WHEELS

Transport wheels allow you to easily and effortlessly relocate the rammer on the jobsite without the need of any larger machine for transportation. The wheel wagon is simply clicked underneath the rammer and the machine is ready to be driven around. No time-consuming mounting is needed!



HOUR METER

With the optional working-hour meter to add to your ACR Rammer, you are always in control of the working hours of your machine, and you know when the next service needs to be done. A feature also attractive for rental companies.

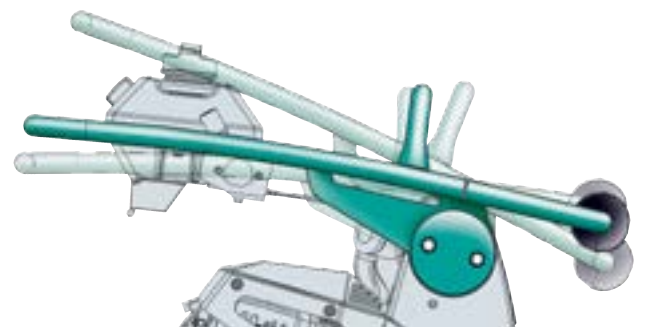

HEIGHT ADJUSTABLE GUIDE HANDLE

The guide handle is adjustable in height for an optimal working height for each operator. The handle is vibration-isolated to keep the vibration for the operator at a minimum.

VARIETY OF SHOES

ACR Rammers are available with a large variety of different shoes, offering a solution for all application. The range for ACR 60 & ACR 68 include seven working widths, three selective working heights and an asymmetric foot that allows working along curbs and walls without tilting the machine. The ACR 70 D features three different working widths.



Easy to exchange, only 4 screws

340 mm asymmetric: compaction work in trenches protected by shuttering systems without inclining the rammer during operation

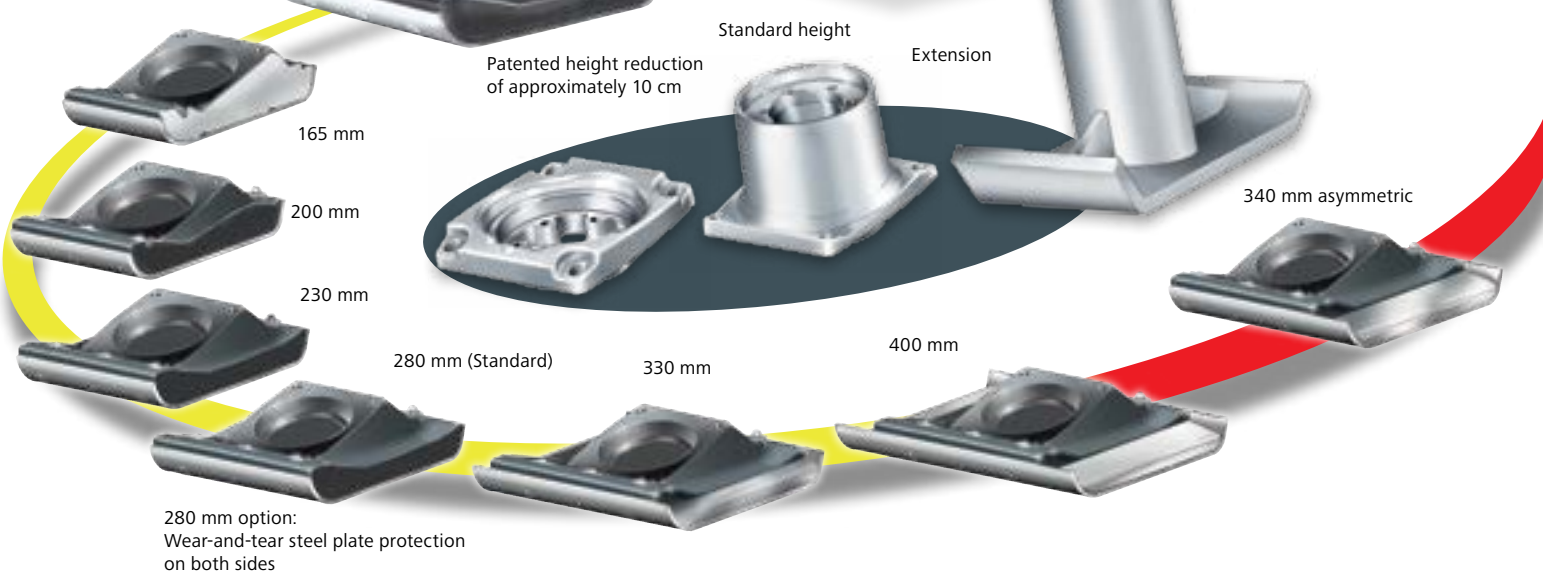

ACR 60

THE HANDLE AND THE HEIGHT MAKE THE DIFFERENCE

The ACR 60 is the lightest of the Ammann Rammers, with a weight of 62 kg. It is used when a little less weight is sufficient – especially in particularly tight spaces.

Like all Ammann Rammers, the handle is a key factor for the success of the ACR 60. It offers high production while limiting the vibration levels that reach the operator and, of course, enables manoeuvrability.

The rammer is equipped with a Honda GX100, 4-stroke petrol engine that is powerful and also prevents fluid spills when on steep grades. The engine meets all global emission standards. In addition, the ACR 60 is available with a GXR120 reduction engine that also fulfils all requirements for trench works.

ACR 68

A RELIABLE PERFORMER

The ACR 68 is the rammer of choice for contractors who need heavier compaction yet also prefer a machine with a petrol engine. Despite the larger working weight, the machine keeps its leading balance.

The rammer, with a weight of 68 kg, is equipped with a Honda GX100, 4-stroke petrol engine that is powerful and meets all global emission standards. The ACR 68 also is offered with the Honda GXR120 petrol engine, which provides the same benefits as the GX100 but adds more power with lower emissions.

HIGHLIGHTS

- Best-in-class drive
- Voluminous air filter with self-cleaning feature that when combined with optional cyclone pre-filter extends service intervals to five times that of some competitors
- Sure-grip, vibration-insulated guide handle for fatigue-free operation
- Patented height reduction of approximately 10 cm using adapter plate option
- Corrosion-free fuel tank as a standard
- Standard 280 mm foot, with seven sizes available including an asymmetric option for compaction along walls and curbs
- Powerful and robust single-spring system
- Easily accessible recoil starter
- Throttle adjustment with automatic idle
- Robust crank drive
- Wear-resistant ramming shoe with integrated steel plate
- Additional rollers and grips for easy loading and unloading



ACR 70 D

DIESEL POWERED COMPACTION

The ACR 70D provides the most rammer weight, at 83 kg. It utilises a YANMAR L48 diesel engine that is popular with contractors who are seeking to have light equipment with diesel engine – and of course want power, too.

The rammer features an adjustable, vibration-resistant handle that helps fight fatigue and keep the operator focused throughout a shift.

The added weight combined with the low centre of gravity and the YANMAR engine provide plenty of compaction pop.

HIGHLIGHTS

- Sure-grip, vibration-insulated guide handle for fatigue-free operation
- Corrosion-free fuel tank
- Powerful and robust single-spring system
- Easily accessible recoil starter
- Throttle adjustment with automatic idle
- Wear-resistant ramming shoe made of high quality plastic with integrated steel plate
- Additional rollers and grips for easy loading and unloading



SPECIFICATION

ACR RAMMERS

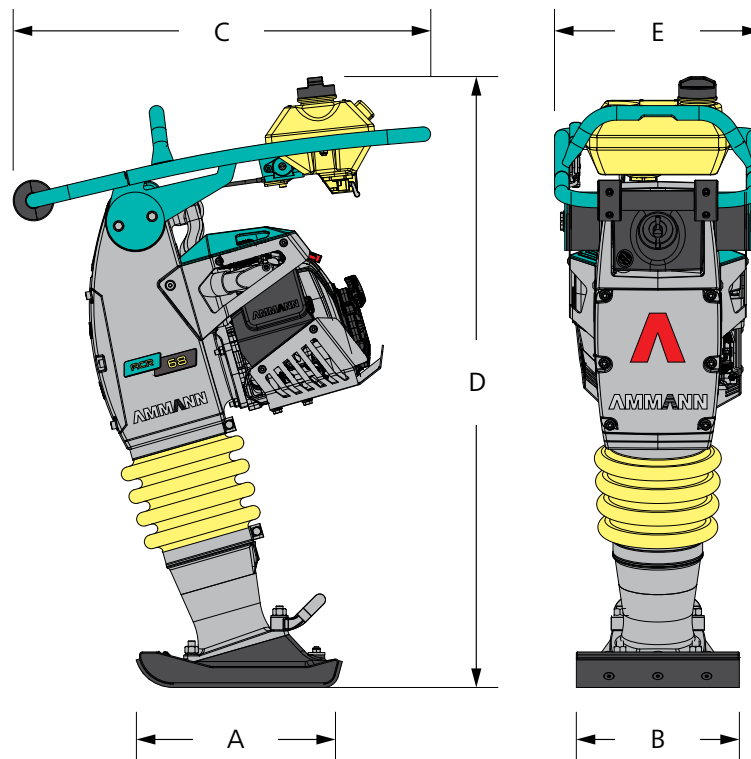

WEIGHT & DIMENSIONS

	ACR 60	ACR 68	ACR 70D
MACHINE WEIGHT	62 kg	68 kg	83 kg
A FOOT LENGTH	340 mm	340 mm	340 mm
B FOOT WIDTH	280 mm	280 mm	280 mm
C HANDLE LENGTH	710 mm	710 mm	670 mm
D MACHINE HEIGHT	1020 mm	1020 mm	980 mm
E HANDLE WIDTH	355 mm	355 mm	360 mm

ENGINE

	Honda GX 100 / Honda GXR 120	Honda GX 100 / Honda GXR 120	Yanmar L48 AE
ENGINE	Honda GX 100 / Honda GXR 120	Honda GX 100 / Honda GXR 120	Yanmar L48 AE
FUEL	Petrol	Petrol	Diesel
ENGINE OUTPUT	2.2 kW (3 HP) / 2.7 kW (3.7 HP)	2.2 kW (3 HP) / 2.7 kW (3.7 HP)	4.3 HP / 3.2 kW
AT RPM	4300	4300	3250

COMPACTION FORCES

PERCUSSION RATE	680 bpm	680 bpm	730 bpm
STROKE HEIGHT	65 mm	65 mm	60 mm
CENTRIFUGAL FORCE	11.5 kN	13 kN	16 kN
SURFACE CAPACITY	225 m ² /h	225 m ² /h	210 m ² /h
MAX. COMPACTION PERFORMANCE*	45 cm	50 cm	60 cm

MISCELLANEOUS

FUEL TANK CAPACITY	3.2 l	3.2 l	2.5 l
TRAVEL SPEED	13.5 m/min	13.5 m/min	12 m/min
OPTIONAL FOOT SIZES WIDTH	165-200-230-330-400 mm	165-200-230-330-400 mm	230-330 mm

*depending on ground conditions